

# B.L. WALLACE-DISTRIBUTOR, INC.

8542 La Salle St., Cypress, CA 90630 Phone (714)761-2071 FAX (714)761-0460  
www.blwallace.com

- Etched polypropylene face
- Face anchored in concrete
- Ultra-violet inhibitor
- Exceeds ASTM-D1693 Standards for Environmental Stress Cracking Resistance

## Curb Valve Box No. F22 BOX 38 lbs.

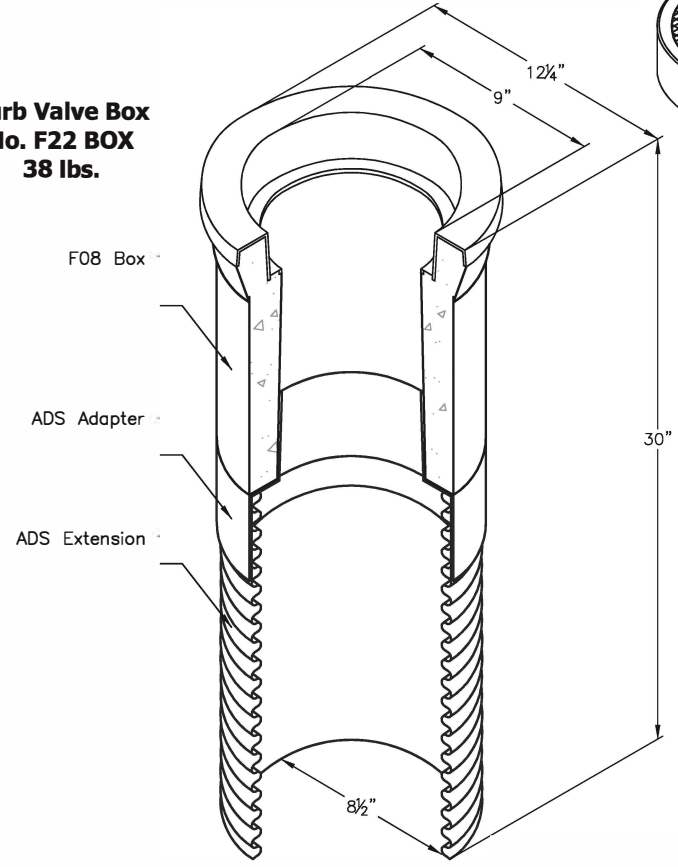

## Reinforced Concrete Lid No. F08R 8 lbs.

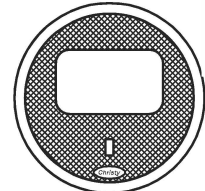
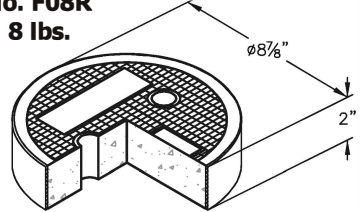

**FLO8D**

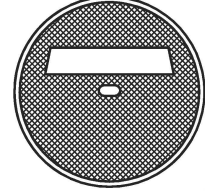

**F08C**

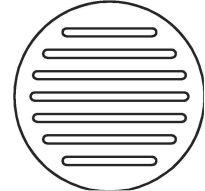

**V01-71C**

A high density reinforced concrete box with non-settling shoulders positioned to maintain grade and facilitate back filling. Approximate dimensions and weight shown.

Oldcastle Ordering Code	Item	Approx. Shipping Weight	Description
F08BOX	BOX	38 lbs.	F08 concrete box (to make F22 add ADS Extension and Adapter)
F08R	LID	8 lbs.	Reinforced Concrete Lid with Plastic Ring
F08C	LID	8 lbs.	Cast Iron Lid
FLO8D	LID	2 lbs.	Fibrelyte Lid, Non-Concrete
V01-71C	LID	12 lbs.	Cast Iron Lid ADA Compliant
F08XAD	ADAPTER	1 lbs.	ADS Snap Adapter
F22XP18	EXTENSION	3 lbs.	ADS 18" Plastic Extension
F08XP120	EXTENSION	11 lbs.	ADS 10' Plastic Extension



<b>F22 BOX</b>
FILE NAME: F22_JS0
ISSUE DATE: January, 2011

**F22 CURB VALVE BOX**  
**8" I.D. x 30"**  
**CHRISTY'**