

# B.L. WALLACE-DISTRIBUTOR, INC.

8542 La Salle St., Cypress, CA 90630 Phone (714)761-2071 FAX (714)761-0460  
www.blwallace.com

● Drainage Box is H/20 rated

**Cast Iron Grate  
No. V12-71W  
34 lbs.**

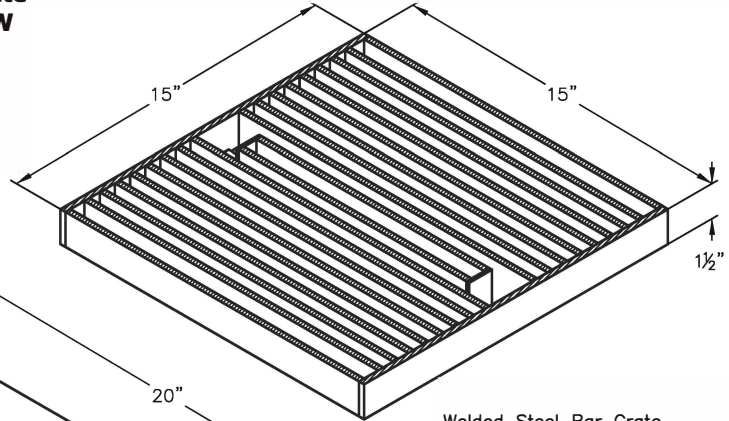

**Drain Box  
No. V12 BOX  
177 lbs.**

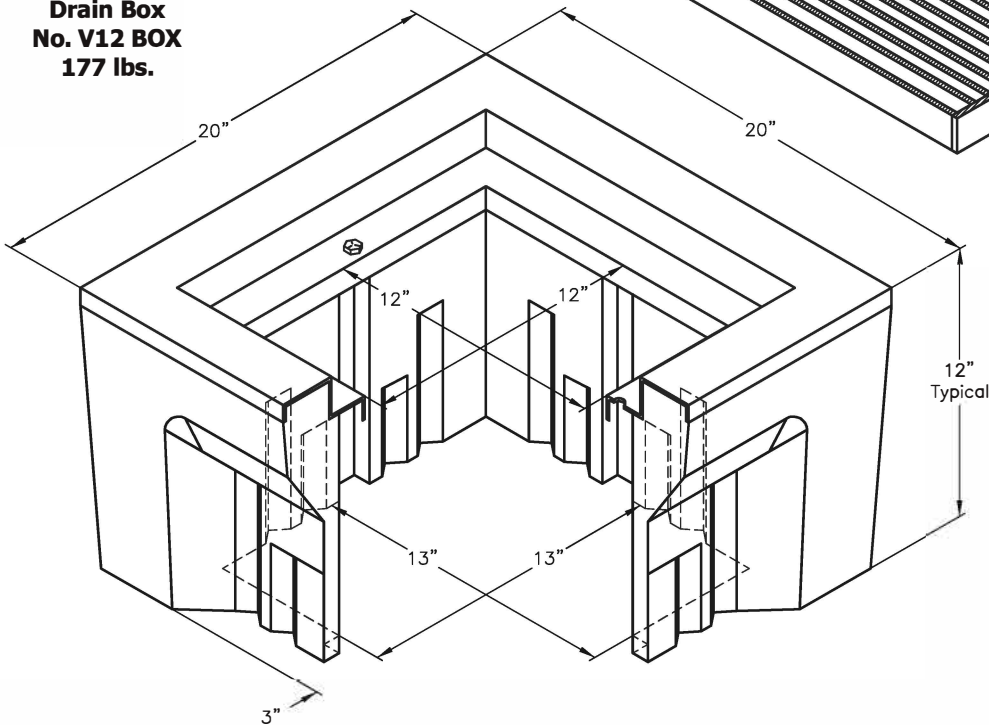

Welded Steel Bar Grate  
is ADA Approved.

A high density reinforced concrete box with cast in galvanized frame, specifically engineered for heavy traffic areas. Approximate dimensions and weight shown.

Oldcastle Ordering Code	Item	Approx. Shipping Weight	Description
V12BOX	BOX	177 lbs.	V12 Drain Box (12" x 12") - H/20 Loading, Bolt Down, Interchangeable with Brooks #1212 Box- 12 per pallet
V12-71W	LID	34 lbs.	Welded, Steel Cross Bars, H/20 Loading, Galvanized; ADA Approved
V12X12	EXTENSION	120 lbs.	12" Reinforced Concrete - 12 per pallet



## V12 BOX

FILE NAME: V12\_JS0

ISSUE DATE: January, 2011

## V12 DRAIN BOX

12" x 12"

CHRISTY

DRAINAGE