

# B.L. WALLACE-DISTRIBUTOR, INC.

8542 La Salle St., Cypress, CA 90630 Phone (714)761-2071 FAX (714)761-0460  
www.blwallace.com

- Etched polypropylene face
- Face anchored in concrete
- Ultra-violet inhibitor
- Exceeds ASTM-D1693 Standards for Environmental Stress Cracking Resistance

## DRAIN BOX No. V01BOX 34 lbs.

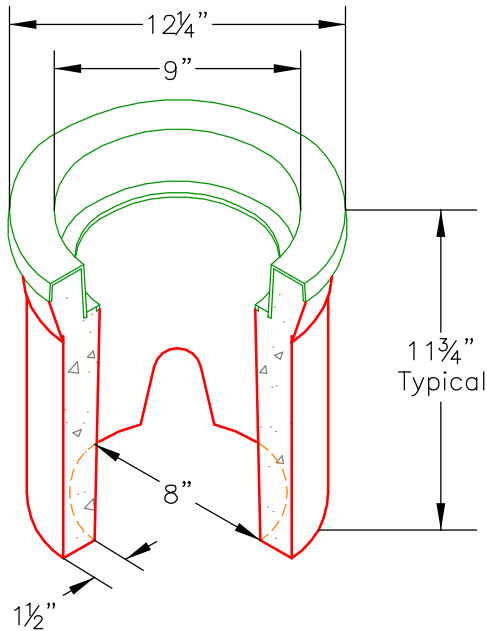

## REINFORCED CONCRETE LID No. F08R 8 lbs.

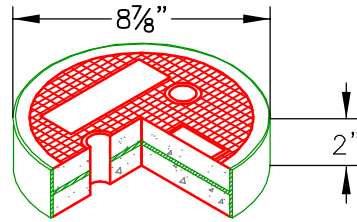

**F08C**



**V01-71C**

A reinforced concrete dual purpose box designed for either light purpose drainage installations or enclosing sewer cleanouts in foot traffic areas. Tapered shoulders prevent settling. Notch accommodates up to approximately 4" O.D. pipe or drain tile. Approximate dimensions and weight shown.

Ordering Code	Item	Approx. Shipping Weight	Description
F08BOX	BOX	34	V01 Drain Box (8" I.D. x 12")- 48 per pallet
F08R	LID	8	Reinforced concrete lid with plastic ring
F08C	LID	8	Cast iron
V01-71C	GRATE	12	Cast iron



**Oldcastle Precast**<sup>®</sup>  
Enclosure Solutions  
MADERA/ROSEVILLE/TRACY

Copyright © 2009 Oldcastle Precast Inc.

### V01 BOX (STANDARD)

FILE NAME: V01\_ISO

ISSUE DATE: January, 2009

### V01 DRAIN BOX 8" I.D. x 12

