

B.L. WALLACE-DISTRIBUTOR, INC.

8542 La Salle St., Cypress, CA 90630 Phone (714)761-2071 FAX (714)761-0460
www.blwallace.com

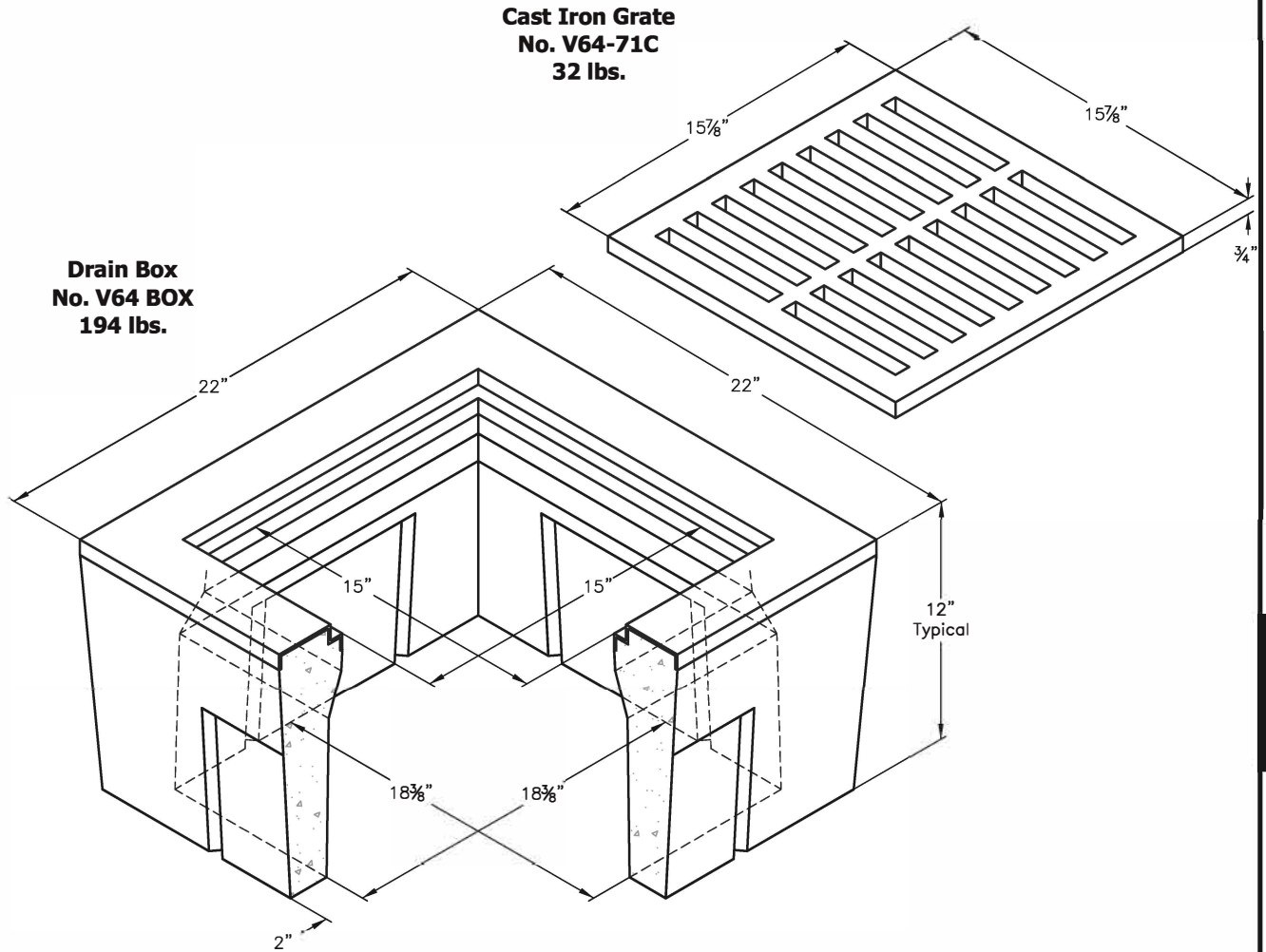

DRAINAGE

This concrete drain box has a cast in galvanized frame and is specifically engineered for drainage in medium areas such as parking lots, school grounds, walkways, ect. Its design permits final grading material to "lock in" and finish clean. Knock-outs accommodate up to 8" O.D. pipe. Approximate dimensions and weight shown. ADA approved grates available upon request.

Oldcastle Ordering Code	Item	Approx. Shipping Weight	Description
V64BOX	BOX	194 lbs.	V64 Drain Box (18 3/8" x 18 3/8") - 12 per pallet
V64-71C	LID	32 lbs.	Cast Iron Grate - ADA Compliant available upon request
V64X12	EXTENSION	152 lbs.	12" Reinforced Concrete - 12 per pallet



V64 DRAIN BOX

FILE NAME: V64_ISO

ISSUE DATE: January, 2011

**V64 DRAIN BOX
18-3/8" x 18-3/8"
CHRISTY'**